



Company Profile 2026

The Full Business Solution 

Prepared By :
Fascom
Dar es salaam, Tanzania
P.O. Box 21267





FASCOM INVESTMENT LIMITED welcomes our commitment to quality, reliability, water systems and automotive supply

We take pride in delivering trusted products through strong partnerships, ensuring and long-term value for every client we

Table Of Contents

01	Company Overview
02	Our Mission & Vision
03	Core Operation & Why choose us
04	Our Product
05	Problem & Solution
06	Our Team
07	Clients & Partners

comes you to explore
and innovation across
solutions.

products and services
efficiency, durability,
serve.

Company Overview

About Our Company

FASCOM INVESTMENT LIMITED is a dynamic and diversified supply and assembly company based in Dar es Salaam, Tanzania. We specialize in delivering high-quality solutions in water management systems and automotive parts supply, bridging international markets with local demand.

With a strong commitment to quality, reliability, and efficiency, FASCOM plays a critical role in supporting infrastructure development, water distribution, and mobility solutions across Tanzania and the region.

We operate at the intersection of engineering solutions and international trade. Our business focuses on:

- Assembly and supply of water meters and accessories
- Supply of valves, pumps, and water system components
- Import and distribution of automotive spare parts and lubricants

We collaborate with global manufacturers and local stakeholders to ensure that our products meet both international standards and local environmental conditions.



“
Delivering reliable engineering solutions and trusted supply partnerships that drive efficiency, sustainability, and long-term value.”

Mission & Vision



Mission

To deliver quality, reliability, and value by expertly assembling water systems and supplying premium automotive parts sourced from trusted global partners.

Vision



To become the preferred partner for essential industrial and automotive supplies in Tanzania and the wider region.

FASCOM INVESTMENT LIMITED

Engineering Products & Services

A white icon of a speech bubble and two people, representing communication and support.

- Reliable Supply
- Technical Support

FASCOM INVESTMENT LIMITED combines technical expertise with strong global sourcing capabilities to deliver durable and cost-effective solutions

Our focus on quality assurance, efficient logistics, and customer satisfaction ensures consistent performance across all projects, from small-scale installations to large infrastructure developments.

Core Operations



Water Systems Assembly & Supply

FASCOM INVESTMENT LIMITED provides reliable and efficient water system solutions tailored for residential, commercial, and municipal applications. Our assembly and supply operations focus on delivering durable, accurate, and high-performance components that meet both international standards and local environmental conditions.

We ensure consistent quality through strong partnerships with global manufacturers and strict quality control processes.



Water meters

We provide advanced multijet water meters (dry dial, IP68, MID certified) designed for high accuracy, durability, and long service life. These meters are suitable for both domestic and utility applications, ensuring reliable measurement even at low flow rates.



Valves

Our range includes bib cocks, gate valves, and related accessories used in water distribution systems. These products are built for corrosion resistance, leak prevention, and efficient flow control.



Pumps and motors

We supply high-performance pumps and motors that ensure efficient water movement across various systems. Our solutions are suitable for residential, commercial, and industrial applications, offering reliability and energy efficiency.



100%
Reliable Water
System Solutions

FASCOM is committed to delivering durable and efficient water infrastructure components that enhance system performance, reduce losses, and support sustainable water management.

Why Choose Us ?

Customer-Centric Focus

At FASCOM INVESTMENT LIMITED, we prioritize our clients by delivering solutions tailored to their specific needs. We work closely with customers to understand their requirements and provide reliable, cost-effective products and services that enhance efficiency and performance.

Our commitment to quality, reliability, and long-term partnerships sets us apart. We combine technical expertise with strong international sourcing capabilities to deliver products that meet both global standards and local environmental conditions. From water infrastructure to automotive solutions, we ensure consistent performance, durability, and value in every project we undertake.

- High-quality products meeting international standards (ISO, OIML, MID compliant)
- Strong global sourcing network (UAE, Japan, and international partners)
- Durable solutions designed for African operating conditions
- Reliable supply chain and timely delivery
- Flexible solutions for both urban and rural applications.
- Strong global sourcing network (UAE, Japan, and international partners)
- Durable solutions designed for African operating conditions
- Reliable supply chain and timely delivery



Reliable Supply & Consistency

We ensure reliable product availability through strong sourcing and efficient logistics.



Quality You Can Trust

We deliver durable solutions that ensure long-lasting performance and lower operational costs.

Our Products

FASCOM INVESTMENT LIMITED in collaboration with FasFlow meters, brings you the best meters that comply with the local and global standards and are compatible with all sorts of environmental conditions.

Product Overview

As per EWURA classification of water meters, Multijet water meters are called such because the water impacts the impeller at multiple points around its perimeter instead of doing it at a single point. Available in form of a dry dial or wet dial. Applicable for small (Diameters typically range from 15 to 150 mm). Adequate for hard water with suspended particles. Mainly used for domestic applications, and are normally more cost effective than single jet meters in diameters larger than 20 mm. The accuracy of multijet meters is not affected much by changes in the velocity profile.



MTW IP68 R160/R200 Brass Multijet Dry type

High-accuracy brass multijet water meter designed for long service life, low pressure loss, and reliable performance in domestic and utility applications.



TG Brass Multijet Dry type IP68 R160/R200

Durable brass multijet meter with IP68 protection, offering stable measurement, resistance to harsh conditions, and excellent low-flow sensitivity.



MTW IP68 R160/R200 Brass Multijet Plastic type

Advanced multijet water meter engineered for precision and durability. Features include high sensitivity at low flow, corrosion-resistant body, anti-magnetic protection, and optional AMR/pulse output for modern water management systems.

**MTW IP68 R16I/R200
Brass Multijet Dry type**



**TG Brass Multijet Dry type
IP68 R160/R200**

**MJ-SDC-E Plastic Multijet
Dry type R160/R200**



FEATURES



Durability & Protection

- IP68 protection for harsh environments
- Reinforced glass resistant to pressure and impact
- Corrosion-resistant brass body (for brass models)

Efficient Flow & Accuracy

- Multi-jet working principle ensures long service time
- Low pressure loss with high sensitivity at initial flow
- MID certified for measurement accuracy

Security & Reliability

- Protection against external magnetic fields
- Non-return valve and filter available
- Vacuumed mechanism for stable performance

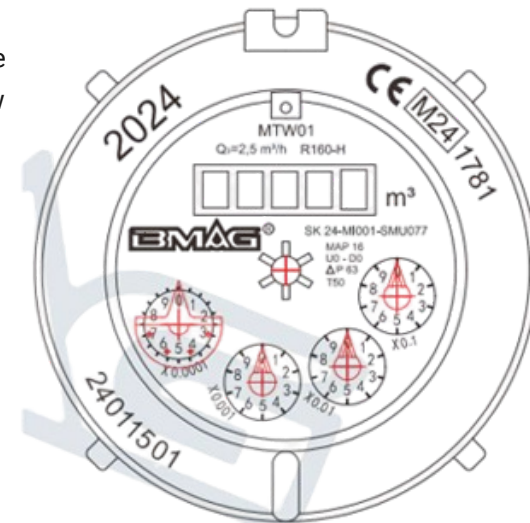

DIMENSION

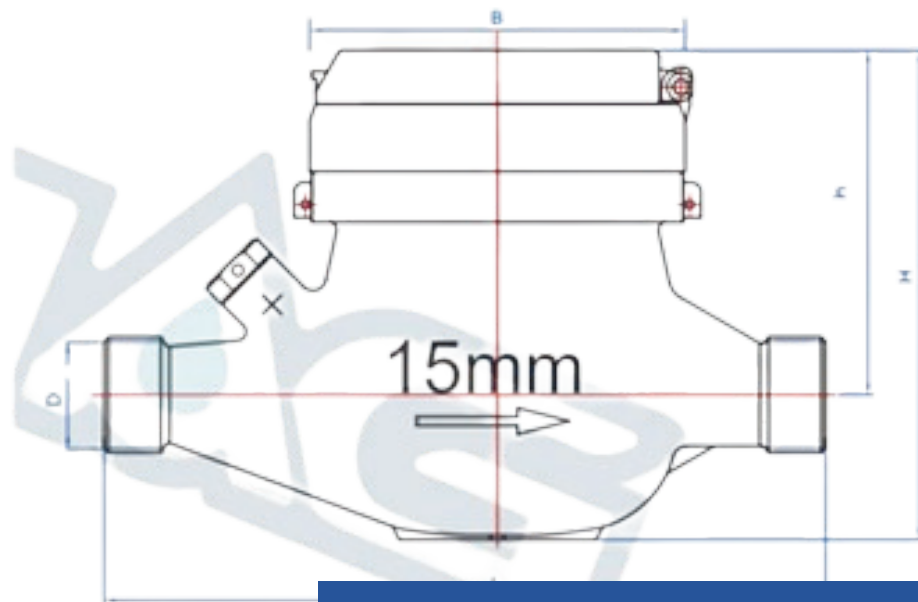

Size	DN15	DN20	DN25	DN32	DN40	DN50
L (mm)	165/190	190	225/260	260	300	300
D	3/4	1	1-1/4	1-1/2	2	2-1/4
h	79	79	81	81	98	98
B (mm)	87	87	92	92	113	113
H (mm)	112	112	121	121	152	152

Low Maintenance & Long-Term Performance

Designed for durability and efficiency, our meters require almost no maintenance while ensuring consistent performance in both domestic and utility applications.

Sales

Designed to meet both local and international standards, our products are suitable for a wide range of applications, making them a reliable choice for utilities and contractors.

Mitigates Risk

Built with anti-magnetic protection and tamper-resistant features, our meters help reduce losses, prevent manipulation, and improve revenue assurance.

Technical Data

Size	Measurement	DN15	DN20	DN25	DN32	DN40	DN50
Overload Flowrate(Q4)	M ³ /h	3.125	5	7.875	12.5	20	31.25
Permanent Flowrate(Q3)	M ³ /h	2.5	4	6.3	10	16	25
Transitional Flowrate(Q2)	l/h	25	40	63	100	160	250
Minimum Flowrate(Q1)	l/h	15.625	25	39.375	62.5	100	156.25
Q3/Q1 (OIML R49)		=<R160=<R80V					
Overload Flowrate(Q4)	M ³ /h	3.125	5	7.875	12.5	20	31.25
Permanent Flowrate(Q3)	M ³ /h	2.5	4	6.3	10	16	25
Transitional Flowrate(Q2)	l/h	20	32	50.4	80	128	200
Minimum Flowrate(Q1)	l/h	12.5	20	31.5	50	80	125
Q3/Q1 (OIML R49)		=<R200=<R100V					
Mounting on the network/installation		Horizontal/vertical					
Max. Reading	m ³	99999.9999			999999.9999		
Min. Reading	Liter					0.02	
Max. Working Pressure	bar					16	
Max. Working Temperature	°C					50	
Pressure Loss	bar					0.63	



100%
High Accuracy
Compliance

FASCOM meters comply with OIML R49 standards, ensuring measurement accuracy within $\pm 5\%$ at low flow (Q1–Q2) and $\pm 2\%$ at normal operating ranges (Q2–Q4).

ACCURACY (MAXIMUM PERMITTED ERROR)

From Q1 inclusive up to but excluding Q2 is $\pm 5\%$.

From Q2 inclusive up to and including Q4 is $\pm 2\%$ for T30 and $\pm 3\%$ for T50.

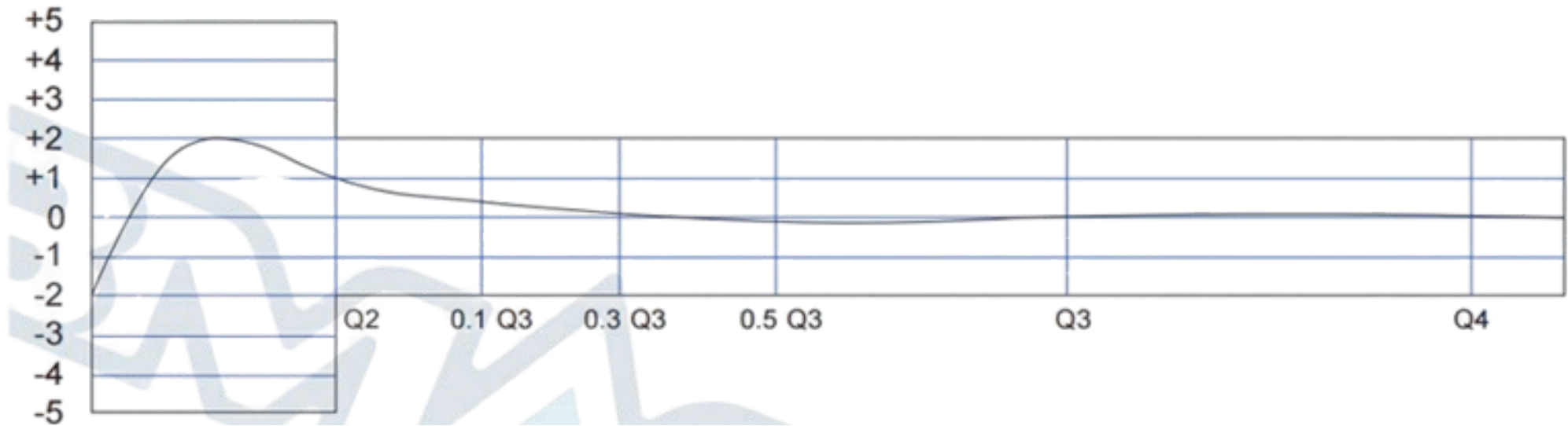

Engineered for precision and durability, our meters maintain stable performance under varying pressure and flow conditions, delivering reliable data for effective billing and system management.

Brass Valves

FASCOM INVESTMENT LIMITED supplies high-quality brass valves designed for reliable flow control, durability, and efficient performance across water distribution systems.

Product Overview

Our brass valves are engineered to deliver consistent performance in residential, commercial, and industrial applications. Manufactured using high-grade, corrosion-resistant materials, they ensure long service life, leak-proof operation, and dependable flow regulation.

Designed to withstand varying pressure conditions, these valves provide secure connections, minimal pressure loss, and reliable operation in demanding environments.



Sweat Full Port Ball Valve

High-performance full port valve designed for maximum flow efficiency, minimal pressure loss, and durable operation in water systems.



PEX x Sweat Brass Ball Valve

Reliable brass valve designed for secure connections, offering strong sealing performance and resistance to wear and corrosion.



Brass PEX x FIP Ball Valve

Durable and versatile valve engineered for efficient flow control and long-term reliability. Designed with precision threads and high-quality brass construction for secure and leak-resistant connections.



BW-G15 Brass lockable gate valve with swivel nut



Copper connection brass gate valve



Union gate valve

Ultrasonic Smart Water Meters

Our smart ultrasonic water meters are designed to deliver high accuracy, reliability, and long-term performance for modern water management systems. Built to operate in demanding environments, they ensure precise measurement, reduced losses, and improved billing efficiency.

Service Overview

We supply advanced smart water meters suitable for residential, commercial, and utility applications. Designed for both urban and rural schemes, these meters enhance transparency, reduce operational losses, and support sustainable water management.



Quality Assurance

All our products meet recognized international standards and undergo strict quality checks to ensure performance, durability, and reliability.



Intelligent Water Measurement

Improved revenue collection, reduced water losses, lower maintenance costs, and enhanced customer satisfaction through accurate and reliable metering.



Why Choose Our Smart Meter?

Reliable performance, high return on investment, and engineered to withstand harsh water conditions, ensuring consistent accuracy and long-term durability.



What You'll Gain

Improved revenue collection, reduced water losses, lower maintenance costs, and enhanced customer satisfaction through accurate and reliable metering.

The Problem



Meter inaccuracies at low flow

Unauthorized tampering and illegal bypass connections remain major challenges, affecting billing accuracy and system accountability. These issues result in financial losses and reduced efficiency in water distribution systems.

High Non-Revenue Water (NRW)

Water utilities face significant losses due to leaks, inaccurate metering, and unauthorized consumption. This reduces revenue and limits the ability to invest in infrastructure improvements.

Meter inaccuracies at low flow

Conventional meters often fail to capture low water usage accurately, leading to under-registration and revenue loss over time. Conventional meters often fail to capture low water usage accurately, leading to under-registration and revenue loss over time.



Our solutions are designed to address key operational challenges in water utilities by improving measurement accuracy, reducing losses, and enhancing overall system efficiency.

The Solution

Advanced Metering Technology

FASCOM provides high-performance multijet water meters designed with high accuracy and excellent low-flow sensitivity, ensuring precise measurement and improved revenue collection.

Durable & Tamper-Resistant Design

Our meters are built with anti-tamper features and robust materials to withstand harsh environmental conditions and prevent unauthorized interference.

Reliable Performance & Long Service Life

Engineered for durability, our products maintain stable calibration over time, reducing maintenance costs and replacement frequency



Delivering accurate, durable, and secure metering solutions that help utilities reduce losses and improve revenue collection.”

Our Team





Sharif Hassan

Shareholder & Managing Director

A Certified Public Accountant (CPA) responsible for financial strategy, compliance, and operational integration, ensuring strong financial governance and sustainability.



Nyamvula Magdalena

Executive Director & Procurement Lead

Leads company strategy and sourcing operations, ensuring high-quality procurement and strong supplier relationships globally.



Feisal Ally

Logistics Manager

Expert in international trade and logistics, overseeing procurement, shipping, and supply chain efficiency across global markets.



Hassan Vuai

Operation Manager

Leading our team with precision and purpose, ensuring smooth operations and strong collaboration



At FASCOM INVESTMENT LIMITED, our strength lies in our people. Our team combines expertise in engineering, procurement, logistics, and finance to deliver dependable solutions in water systems and automotive supply.

Our Clients



Government Institutions

We work with the Government of the United Republic of Tanzania through Water Supply and Sanitation Authorities (WSSA), supporting national water infrastructure and service delivery.



Contractors & Projects

We supply local and regional contractors involved in government and private projects, ensuring timely delivery of quality materials for successful project execution.



Private Sector & Businesses

Our solutions support commercial and industrial clients requiring dependable water systems and automotive components for their operations.



Household Clients

We provide reliable and affordable products to individual homeowners, supporting efficient water use and system reliability at the domestic level.

Our Partners

We collaborate with trusted international manufacturers and suppliers to ensure consistent quality, reliable supply, and access to globally certified products.

Our key international partner, supplying high-quality water meters and components that meet global standards and support our commitment to reliability and performance.



Global Sourcing

Strong international partnerships enable access to high-quality products from established manufacturing hubs.

Reliable Supply Chain

Efficient logistics and procurement ensure consistent product availability and timely delivery.

Quality Assurance

All products sourced through our partners meet international standards, ensuring durability and performance.



Trusted Partnerships

FASCOM INVESTMENT LIMITED builds long-term partnerships based on trust, quality, and shared commitment to delivering reliable solutions for water systems and automotive supply.



FASCOM INVESTMENT LIMITED

Engineering Product and Services.

Contact Us For More Info! 

Phone :

+255 764 220 230

+86 132 5026 3598

+971 55 751 7118

Address :

Dar es salaam, Tanzania

P.O. Box 21267

